

LATCH DETAIL

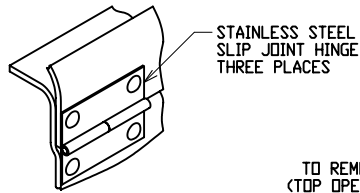

HINGE DETAIL
(TOP CLOSED)

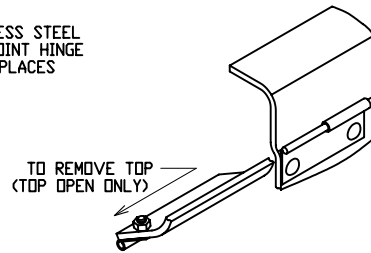

HINGE DETAIL
(TOP OPEN)

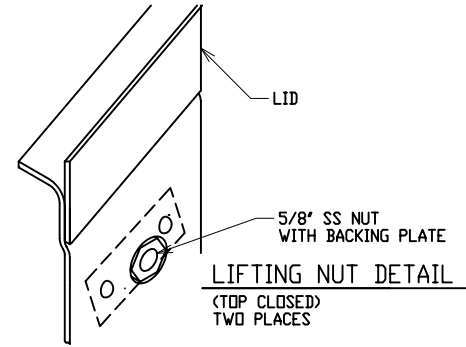

LIFTING NUT DETAIL
(TOP CLOSED)
TWO PLACES

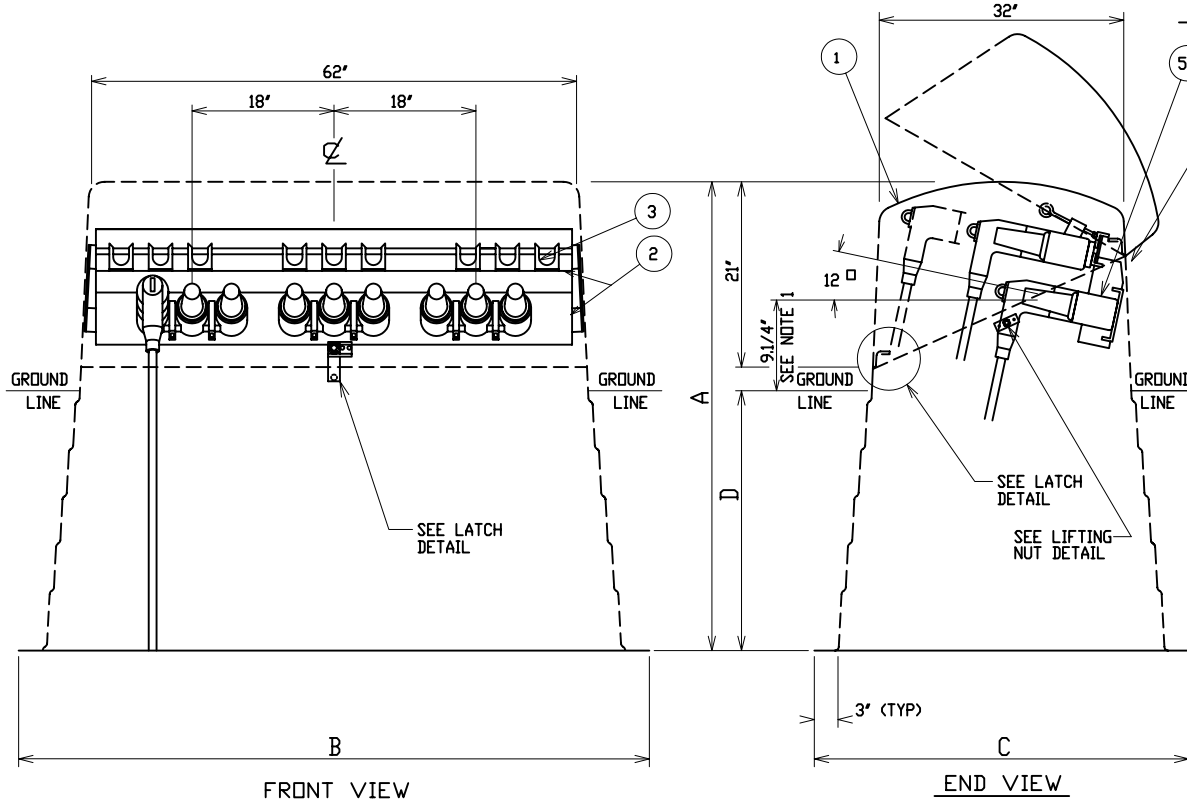

FRONT VIEW

END VIEW

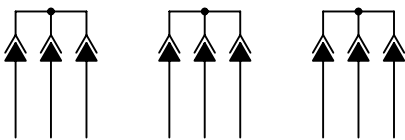

SCHEMATIC

MODEL No.	OVERALL HEIGHT	OVERALL WIDTH AT BOTTOM	OVERALL DEPTH AT BOTTOM	MAXIMUM RECOMMENDED BURIAL DEPTH SEE NOTE 1
	A	B	C	D
CJP-35/A-41	41"	74.1/4"	46.1/4"	17"
CJP-35/A-50	50"	76.1/4"	48.1/4"	26"
CJP-35/A-56	56"	77.3/4"	49.3/4"	32"

MATERIAL LIST - STANDARD UNIT	
ITEM	DESCRIPTION
1	POWER DESIGN INC MODEL NO CJP-35/A FIBERGLASS CABLE JUNCTION PEDESTAL - MUNSELL GREEN
2	ALUMINUM JUNCTION MOUNTING BAR AND PARKING CLIP MOUNTING RAILS
3	ADJUSTABLE LOCATION STAINLESS STEEL PARKING CLIPS

OPTIONAL EQUIPMENT	
51	200 AMP LOADBREAK JUNCTION - 35KV - 150KV BIL - SPECIFY MANUFACTURER AND 2 OR 3-WAY

NOTE:

1. ORDERING INFORMATION:

USER SHOULD SELECT 'D', BURIAL DEPTH, DESIRED. SPECIFY 'A', OVERALL HEIGHT, AS A SUFFIX TO THE BASIC PART NO. i.e., CJP-35/A-50 = 50" OVERALL HEIGHT 9.1/4" TERMINAL HEIGHT MAY BE INCREASED BY DECREASING BURIAL DEPTH OR ORDERING THE NEXT SIZE GREATER 'A' DIMENSION.

2. MATERIAL:

- 1) FIBERGLASS LAMINATE 3/16" NOMINAL THICKNESS
- 2) EXTERIOR UV STABILIZED GELCOAT - 14 MIL NOMINAL THICKNESS - WHITE INTERIOR
- 3) FIRE RETARDANT - DOES NOT SUPPORT COMBUSTION
- 4) STAINLESS STEEL HARDWARE

3. MOUNTING BAR WILL WITHSTAND A MINIMUM 400 L.B. LOADING TO INSTALL OR REMOVE ELBOWS.

4. EQUIPMENT SHOWN IS THE LARGEST INTERFACE THREE PHASE RATED. CLEARANCES MAY BE INCREASED WITH OTHER MANUFACTURER'S EQUIPMENT

DEADFRONT CABLE JUNCTION PEDESTAL

35KV 200 AMP 150KV BIL
THREE PHASE 2 OR 3-WAY LOADBREAK JUNCTION



DRAWN: RB	PAGE	DATE 3-29-04	DRAWING NO. 3361-R1
--------------	------	-----------------	------------------------

FILE REF: